

AM315 BREAD MOULDER

- Sanitary stainless steel construction
- Easy to clean open frame design
- Blue sanitary removable endless conveyor belt, FDA approved
- Removable top cover for easy access to rollers
- Removable, washable moulding plate fabric
- No tools required for disassembly
- Integrated infeed hopper safety
- 120 volt GFCI compliant
- Direct drive motor, 1 HP
- Full motor torque regardless of speed
- No maintenance, lubed for life drive system
- Single Person Operation
- Variable Speed Control

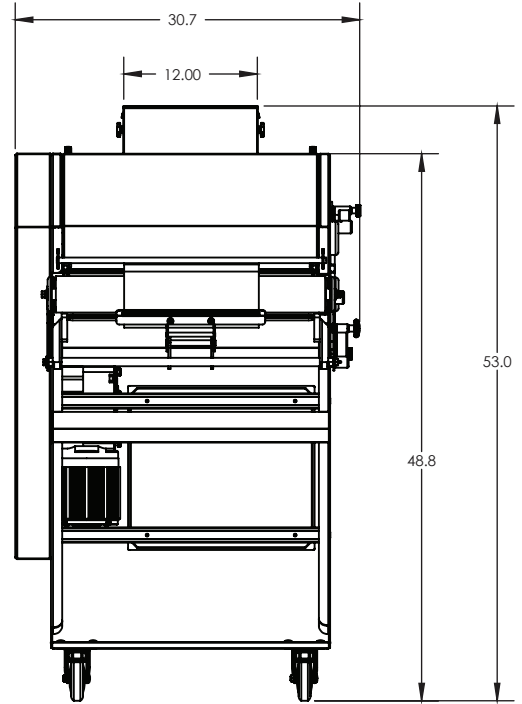

AM315 BREAD MOULDER

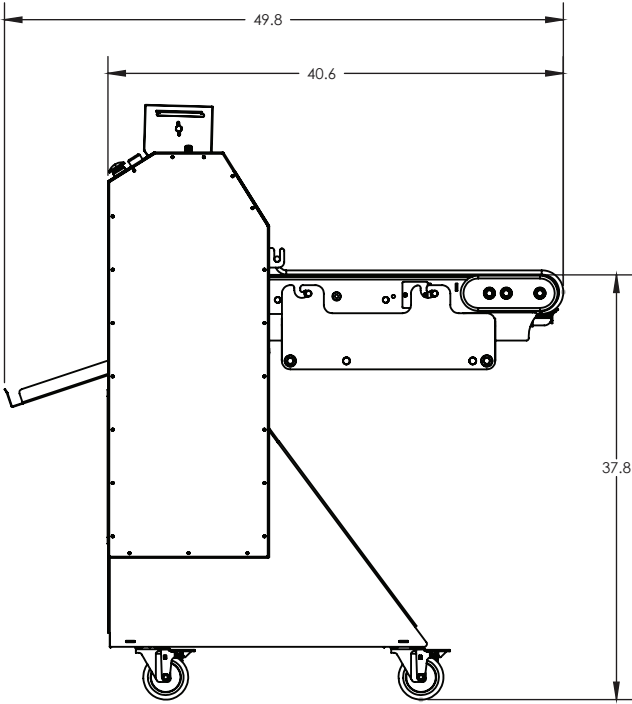

- Removable moulding plate saddle
- Perfect for high hydration dough
- Stick resistant rollers
- Easy access to E stop
- Self-compensating curling chain
- Fully adjustable side guides
- Infeed dough guides for proper dough alignment
- Improved moulding plate dough transition
- 1 oz – 64oz dough pieces
- Exact roller gap in 1/16" increment
- 37.75" conveyor bed height

Dough Tech's artisan bread moulder is designed with the baker in mind. Emphasis has been placed on performance, safety, ergonomics, sanitation and maintenance. The high standards required for artisan dough are now available to every baker and every loaf.

Machine Weight	Shipping Weight	Freight Class	NMFC Code	Amps	Power
480 lbs	625 lbs	Class 85	114440-02	7.2	120/60/1

Continous product development is a Dough Tech policy. Specifications are subject to change without prior notice.

Includes 1 Moulding Plate
Available widths: 6,7,8,9,10,11,12,14,16,18 and 20 inch Moulding Plates