

Product Line	<b>HIGH PRODUCTION ICERS</b>
Model	HI18F, HI24F

VIDEO: <https://vimeo.com/belshaw/icers>

## HIGH PRODUCTION ICERS

Belshaw's HI-series Icers provide fast, uniform icing of cake and yeast-raised donuts – and any product under 2 inches in height – without the use of hands to touch the product or icing.

- Full screens (or baking pans) can be iced in seconds. Special skills are not needed – consistent, uniform icing can be applied by a novice. Easy changeover to different flavors is accomplished by using extra icing pans. Floor models occupy little space and are moveable on casters.
- **HI-18F** accommodates approximately 24 donuts on 17" x 25" glazing screens. Also accepts standard 18" x 26" baking pans. Capacity of the HI18F is approximately 120 dozen donuts per hour.
- **HI-24F** accommodates approximately 36 donuts on 24" x 24" glazing screens such as Belshaw # HG24-0001. Capacity of the HI18F is approximately 180 dozen donuts per hour
- The HI18 and HI24's unique donut handling system submerges one side of the donuts in the icing. The finished product is uniformly iced, with minimum of drips, and without immersing the screen. Hand contact is only used to arrange the donuts on the screen or pan. The finished product is immediately ready for display.
- Icing is held in a large capacity Icing Pan and warmed indirectly by a low wattage, uniform radiant Heating Panel.
- Heavy-duty construction and sound design facilitate cleaning and provide a durable product that will stand up to years of everyday use.
- For high capacity production, 2-5 icers may be used simultaneously.

### Electronic temperature controller

- HI18F and HI24F both feature an electronic temperature controller to manage icing temperature. The controller operates as a highly accurate thermostat, and allows the operator to monitor temperature on a clear LCD display.
- Temperature is measure by a temperature probe which is can be inserted anywhere.

### Accessories

- **Extra Icing Pans.** These allow operators to store different icing flavors in separate Icing Pans, ready to insert them when needed into the HI18-24 Icer's Heating Panel. (If 3 icing flavors are used, 2 extra Icing Pans may be ordered to make a total of 3).
- **Heating Panels.** Used to quickly warm an Icing Pan containing donut icing (as described above). Before icing donuts, the icing to be used must be warm. An extra Heating Panel can be used to warm whichever icing flavor is to be used next. Icing flavors can then be changed in less than a minute.
- **Screens**
  - 17" x 25" Part Nbr SL200-0004 Holds 24
  - 24" x 24" Part Nbr HG24-0001 Holds 25–36 (dependent on size)



HI18F Icer (with electronic temperature controller)



Left: HI18F Icer (holds 18"x25" glazing screen with 2 dozen donuts)  
Right: HI24F Icer (holds 23"x23" screen with 3 dozen donuts)



Donuts iced with HI24F Icer

Product Line	<b>HIGH PRODUCTION ICERS</b>
Model	HI18F, HI24F

### FRONT VIEW

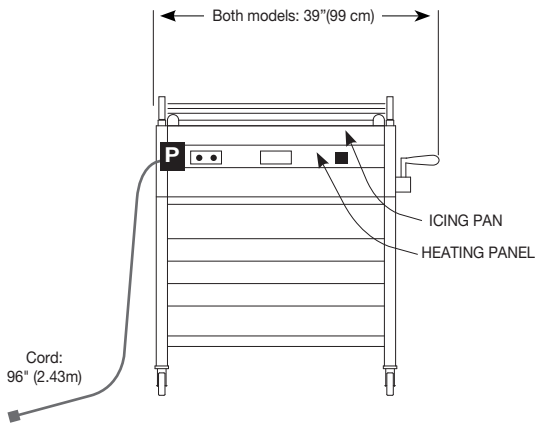

### SIDE VIEW

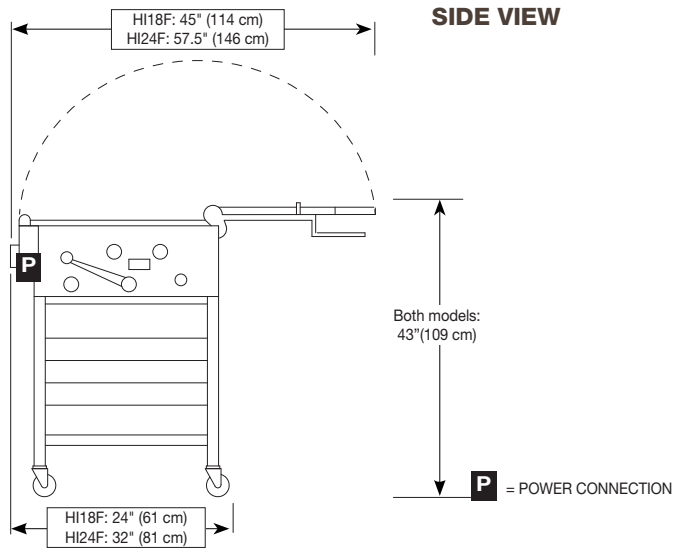

### STANDARD FEATURES

- Heavy duty construction of stainless steel and aluminum.
- Stainless steel icing pan, easily removable for quick changeover to other flavor icings
- Storage shelves for 3 additional Icing Pans or Heating Panels
- Easy to read, easy to set electronic controller with thermostatic control
- 4 casters, 2 lockable
- 6 extra wires included for donut retainer frame (Part # HI18-0046)
- Removable components for easy cleaning. Cleanable in rack washer, after removing heating unit
- 120V or 240V models available for worldwide usage

### CERTIFICATIONS



- Standard North America models are certified by ETL to UL-197, and by NSF to NSF-4
- CE models available for European Union and other countries.

ACCESSORIES	HI18F	HI24F
Glazing Screens	SL200-0004	HG24-0001
Icing Pans	HI18-0001	HI24-0006
Heating Panel (120V)	HI18-1300	HI24-1300
Heating Panel (240V)	HI18-1300-240CE	HI24-1300-240CE

### SPECIFICATIONS

		HI18F	HI24F
<b>COMPATIBLE GLAZING SCREENS</b>	inches	17" x 25"	24" x 24"
	part number	SL200-0004	HG24-0001
<b>BAKING PAN SIZE</b>	inches	18" x 26"	24" x 24"
<b>ICING PAN CAPACITY</b> <i>(Approximate)</i>	lbs	50 lbs	60 lbs
	kg	22.7 kg	27.3 kg
	gallons	7 gal	8.3 gal
	liters	26 L	31.3 L
<b>ELECTRICAL DATA</b> <i>(specify voltage at time of order)*</i>			
<b>120V, 60hz, 1ph</b>	amps	7.5 A	10 A
	kilowatts	0.9 KW	1.2 KW
<b>240V, 50/60hz, 1ph</b>	amps	4 A	5 A
	kilowatts	1 KW	1.2 KW
*If extra heating panel is purchased, it requires a separate power connection			
<b>PLUG</b>	120V	NEMA 5-15P	
	240V N.America	NEMA 6-15P	
	240V International	Not supplied	
<b>CORD</b>	length	96 inches (2.5 m)	
<b>SHIPPING DIMENSIONS</b> <i>(Approximate, shipped in carton on pallet or crate)</i>	inches	48" x 40" x 54"	48" x 40" x 54"
	cm	122x102x137 cm	122x102x137 cm
	lbs	218 lbs	276 lbs
	kg	99 kg	125 kg
<b>FREIGHT CLASS</b>		100	100

90 Years of Quality Donut & Bakery Equipment

[www.belshaw.com](http://www.belshaw.com)



**BELSHAW ADAMATIC BAKERY GROUP** 814 44th St NW, Suite 103, Auburn, WA 98001  
 Phone 800.578.2547 • (+1)206.322.5474 **Customer Service** info@belshaw.com **Technical Support** service@belshaw.com

©2017 Specifications are subject to change **Current version available from [www.belshaw.com/retail](http://www.belshaw.com/retail)**

an Ali Group Company



The Spirit of Excellence