

Product Line	'EZLIFT' GLAZERS	SPEC HG18EZ-HG24EZ 02-2015
Model	HG18EZ, HG24EZ	

Belshaw's HG18EZ and HG24EZ 'EZLift' style glazers allow fast, uniform glazing of donuts, cinnamon rolls and other baked goods. Both glazers conveniently glaze one full screen at a time with minimal waste.

Belshaw's EZlift method eliminates the heavy lifting associated with standard hand glazers. Rather than being carried by the operator, the glaze applicator slides along rails, and tilts down to fill up with glaze. This design provides even glaze coverage with little strain on the operator.

For glazers with a standard handheld glaze applicator and without rails, choose models HG18C and HG24C.

Standard Features

- HG18EZ glazes 17" x 25" screens (43 x 63 cm) screens.
- HG24EZ glazes 24" x 24" (61 x 61 cm) screens.
- Capacity approximately 30 screens/hour in normal operation
- Kettle has curved interior corners for sanitation.
- Applicator holds glaze to cover a screen of donuts.
- Glaze applicator tilts down for refilling.
- Glaze kettle incorporates 1½" drain with valve to empty surplus glaze.
- Bottom shelf with storage for screens and a large glaze container.
- Washable in rack washer or by hose down
- Stainless steel frame, kettle, applicator, drain and drain tray.
- 4" (100mm) heavy duty water-resistant casters (2 lockable)
- Kettle has curved interior corners for sanitation.
- Listed by NSF for sanitation.

Optional Items

- **Drain Tray.** Reduces floor spillage by allowing one screen of donuts to drip, while glazing another screen. Drain tray is mountable on left or right side. (see below for Part Numbers)
- **Screens.** Glazers accommodate screens shown in table below
- **2" casters.** Choose these smaller casters restrict height of glazer with cover on to 32". (Glazer is otherwise 34")

Model	Part# (Drain Tray)	Part# (Screen)
HG18EZ	HG18EZ-1002	SL200-0004 (17" x 25")
HG24EZ	HG24EZ-0534	HG24-0001 (24" x 24")



HG18EZ Glazer (Glazing screens supplied separately)



HG24EZ Glazer (Screens supplied separately)



EZLift Mechanism – Glaze Applicator on rails



EZLift Mechanism – Tilting to refill applicator



HG18EZ Glazer cover

90 Years of Quality Donut & Bakery Equipment

BELSHAW ADAMATIC BAKERY GROUP

814 44th St NW, Suite 103
Auburn, WA 98001 USA
PART OF ALI GROUP S.P.A.

©Belshaw Adamatic Bakery Group

CONTACT

800.578.2547 (USA/Canada)
(+1) 206.322.5474 Worldwide
service@belshaw.com

WEB

www.belshaw-adamatic.com

Product Line	'EZLIFT' GLAZERS	SPEC
Model	HG18EZ, HG24EZ	HG18EZ-HG24EZ 02-2015

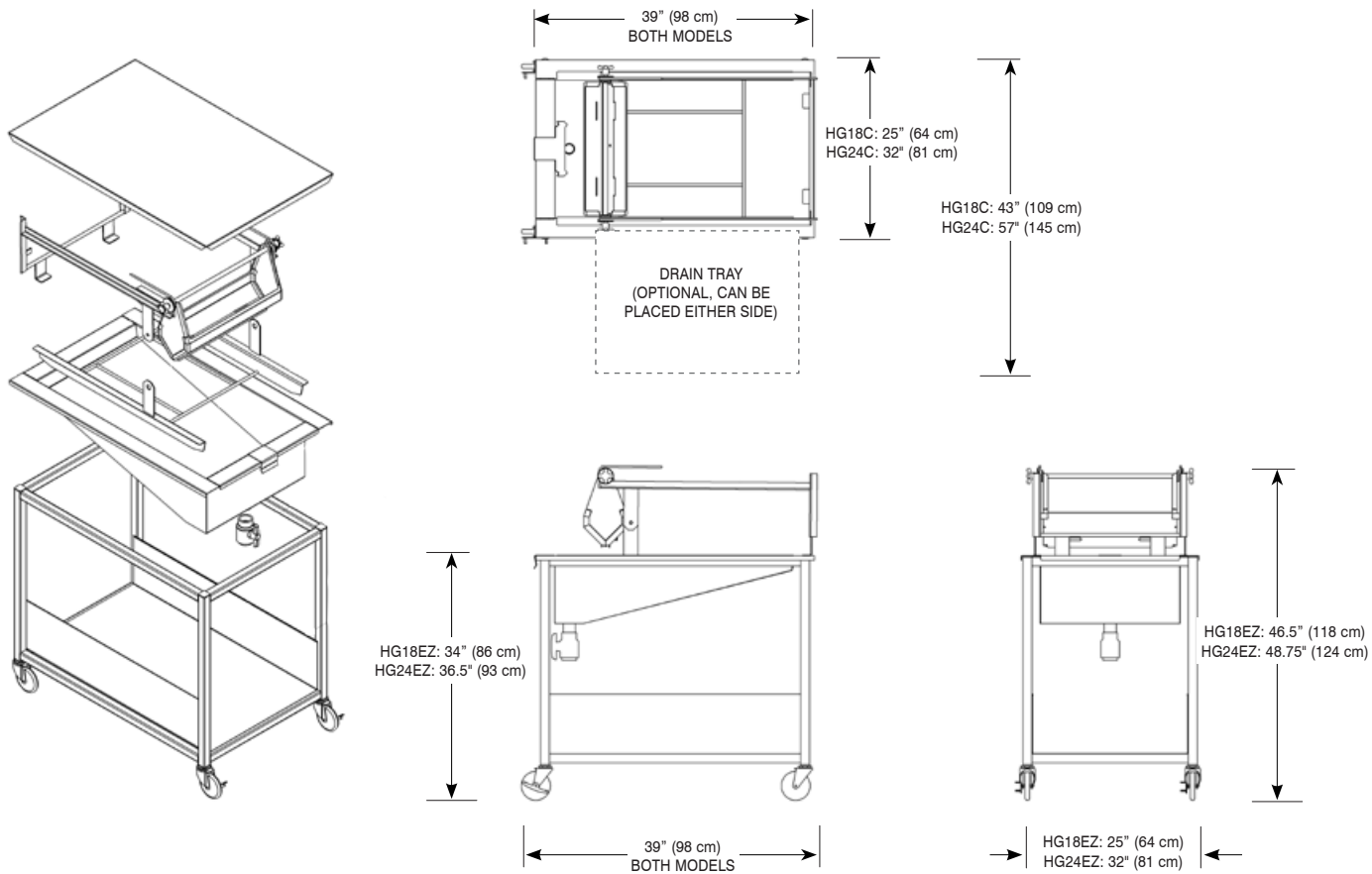

DIMENSIONS

DIMENSIONS		With cover on, EZLift Rails and Applicator stowed		In operation, EZLift rails and applicator in place	
		HG18EZ	HG24EZ	HG18EZ	HG24EZ
<i>(with drain tray removed, or without drain tray. Includes standard 4" caster size)</i>	inches	25" W x 39" D x 34" H	32" W x 39" D x 36.5" H	25" W x 39" D x 46.5" H	32" W x 39" D x 48.75" H
	cm	64 x 98 x 86 cm	64 x 98 x 93 cm	64 x 98 x 118 cm	64 x 98 x 124 cm
SHIPPING DATA <i>(Approximate, shipped in carton on pallet or crate)</i>	inches	40" x 48" x 54"	40" x 48" x 54"		
	cm	102 x 122 x 137cm	102 x 122 x 137cm		
	lbs	169 lbs	209 lbs		
	kg	77 kg	95 kg		
FREIGHT CLASS		150	150		



GLAZING SCREENS (Purchased separately)

		GLAZER MODEL	PART NUMBER (for GLAZING SCREENS)	APPROX. SHIPPING WEIGHT (Carton of 12 screens)
		HG18EZ	SL200-0004	45 lbs (21 kg)
		HG24EZ	HG24-0001	55 lbs (25 kg)
Sample Glazing Screen (made with high quality nickel plated steel)		FREIGHT CLASS: 70 (Screens only)		

90 Years of Quality Donut & Bakery Equipment

BELSHAW ADAMATIC BAKERY GROUP

814 44th St NW, Suite 103
Auburn, WA 98001 USA

CONTACT

800.578.2547 (USA/Canada)
(+1) 206.322.5474 Worldwide
info@belshaw.com

WEB

www.belshaw-adamatic.com