

Retailer Oven

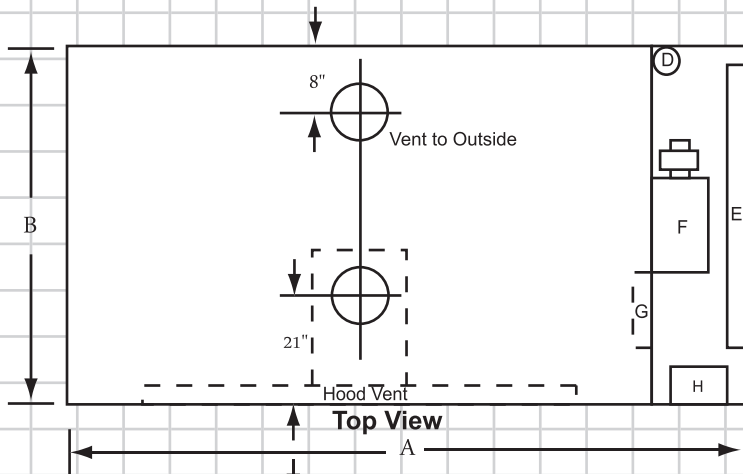

- D Gas connection - Approx. 30" above floor (6.0" IWC - Nat.) (10.0 IWC - LP)
 - E Sliding doors for access to mechanism
 - F 1/4 HP 115v. 1 PH Motor
 - G Cleanout door - Approx 7" above floor
 - H 110 V. 1 PH. Approx 10 Amps. Connection (30" above floor)
- Connections from ceiling should be stubbed in above oven height



Front View

Model*	Bun Pan	A	B	C	Flue Size	Gas Supply	BTU Input	Shipping Weight
4-20 x 28	4	5'	5'-8"	6'-6 1/2"	6"	3/4"	100,000	3,000 lbs
4-20 x 56	8	7'-4"	5'-8"	6'-6 1/2"	6"	3/4"	155,000	4,100 lbs
4-26 x 56	12	7'-4"	7'-5"	6'-10 1/2"	6"	3/4"	155,000	4,700 lbs
6-22 x 56	12	7'-4"	7'-5"	6'-10 1/2"	6"	3/4"	155,000	4,900 lbs
5-26 x 56	15	7'-4"	7'-5"	6'-10 1/2"	6"	3/4"	155,000	4,800 lbs
4-26 x 80	16	9'-6"	7'-5"	6'-10 1/2"	6"	1"	270,000	5,300 lbs
6-22 x 80	18	9'-6"	7'-5"	6'-10 1/2"	6"	1"	270,000	5,800 lbs
6-26 x 92	18	10'-6"	7'-5"	6'-10 1/2"	6"	1"	270,000	6,300 lbs
4-26 x 92	20	10'-6"	7'-5"	6'-10 1/2"	6"	1"	270,000	6,200 lbs
5-26 x 80	20	9'-6"	7'-5"	6'-10 1/2"	6"	1"	270,000	5,900 lbs
5-26 x 92	25	10'-6"	7'-5"	6'-10 1/2"	6"	1"	270,000	6,200 lbs
5-26 x 110	30	12'	7'-5"	6'-10 1/2"	8"	1 1/4"	300,000	6,900 lbs



City of New York
MEA

*Model Indicates: # of Shelves, Depth of Shelves, Width of Shelves

Additional Certifications Required are Responsibility of Owner

