



Donut Depositor Type N

Operator's Manual and Technical Supplement

Belshaw Bros., Inc.
814 44th Street NW, Suite 103
Auburn, WA 98001 USA
Tel: (206) 322-5474
Fax: (206) 322-5425
Toll Free (US): 1-800-578-2547
E-mail: service@belshaw.com
www.belshaw.com





Donut Cutter Type N

Operator's Manual

Belshaw Bros., Inc.

814 44th Street NW, Suite 103

Auburn, WA 98001 USA

Phone: (206) 322-5474 • Fax: (206) 322-5425

Email: service@belshaw.com • <http://www.belshaw.com>

If you accept the machine from the shipping company, you are, in effect, saying that the machine is in good condition, and you must pay for the machine. The freight company has accepted responsibility for the safe delivery of our machines. **For your protection**, inspect the machine to see that no parts are bent, scratched, or otherwise damaged. If any damage has occurred in shipping, file a freight claim with the shipping company immediately.

IMPORTANT

Keep this manual for reference purposes.
--

EQUIPMENT RECORD

Please provide the information below when you correspond with us about your machine.

Purchased by _____

Installed by _____

Date of installation _____ Model number _____

Serial number _____

011108

MN-1542EN

Belshaw Bros., Inc.

814 44th Street NW, Suite 103

Auburn, WA 98001 USA

Phone: (206) 322-5474 • Fax: (206) 322-5425

Email: service@belshaw.com • <http://www.belshaw.com>

Contents

1	Operating	1
2	Cleaning	2
	Care, Maintenance, and Cleaning for Plungers and Hoppers	2
	Care and Cleaning of Cutters and Dispensers	3
3	Maintenance	4
4	Donut Making Helps	6
	Tips on Making Quality Cake Donuts	8
	Tables & Formulas used in Donut Making	9

Preface

The Type N Variety Cutter is designed to cut cake donut products and deposit them in a variety of smaller fryers. It is designed to be mounted on a wall or on a fryer mount.

During production, the operator must move the Cutter, holding the guide handle, to deposit donuts in the desired locations in the fryer. The operator must work safely at all times and read this manual and follow its instructions and warnings.

A thorough understanding of how to install, maintain, and safely operate the Type N Variety Cutter will prevent production delays and injuries. Heed the following warnings and all other warnings that appear in this manual:

- Make sure the machine is mounted securely. Doing so will prevent the machine from tipping over or falling, which could cause serious injury.
- When the machine is column-mounted on a fryer, make sure the fryer is securely fastened to the floor. If the fryer is not fastened to the floor, the weight of the cutter could cause the fryer to tip over, resulting in serious burns, other injury, or death.
- To avoid damaging the machine, never use force to assemble, disassemble, operate, clean, or maintain it.
- Be careful never to get shortening, water, or other materials on the floor. If anything does get spilled on the floor, clean the area immediately. Materials on the floor can cause people to slip or fall, resulting in serious injury or loss of life.

WARNING

Never put your hand in the hopper or between trip arms while machine is being operated.

DANGER!

When the cutter is column mounted, the fryer must be securely fastened to the floor to prevent tipping or overturning the fryer. If the fryer is tipped, SERIOUS BURNS or other injury can occur.

Operation of this machine is very simple, but there are some details to which we would call your attention in order to get the best results, and keep your machine in perfect running condition.

1. See that all lock nuts are kept tight when running machine.
2. Rotate the crank while the machine is empty and see that it runs freely.
3. Set the pointer on the crank to the center of the dial. To do so, loosen the locknut on the crank, hold the dial and move the crank until the required position is reached, then tighten locknut.
4. When shortening has reached the required temperature, fill the hopper $\frac{2}{3}$ full of dough and crank the machine until it has cut two donuts into the mixing bowl. (This expels any air left in the cutting system).
5. Turn the crank to lowest position which raises the pistons and permits the machine to pass freely over the edge of the kettle. With the machine in position over the kettle, begin turning the crank and moving the machine 3 or 4 inches as each donut is dropped.
6. When the required number of donuts has been dropped, turn the crank again to lowest position and swing machine free of kettle.
7. To regulate the weight of the donuts, move plunger rods to highest position which raises one of the pistons out of the cylinder and allows them to move. The dial pointer can now be set to quantity desired and need not be changed until a different size of donut is desired. To make donuts larger, move pointer toward the "L" on the dial. To make donuts smaller, move dial toward the "S."
8. To use up the last of the dough in the hopper, scrape the dough down around the piston rods, and turn crank slower.
9. The machine should be cleaned as soon as possible after use. Disassemble by reversing the assembly procedure. (See Section 1, Installation).

To facilitate packaging, the Variety Cutter has been partially disassembled and before use it should be cleaned and properly assembled.

1. Wash plunger unit in hot water and detergent, rinse and wipe dry. The plunger should be lightly oiled with cooking oil. **CAUTION:** Never oil donut machine parts by dipping in hot fat, unless thoroughly dry.
2. Remove hopper base from hopper by rotating base approximately $\frac{1}{4}$ turn to release lock pin. Then pull down to remove from hopper. Wash both hopper and hopper base in water and detergent, rinse and wipe dry. The cylinder lining in the hopper base should be lightly oiled with shortening.
3. Wash the crank assembly with a cloth dampened with hot water and detergent. Wipe off with another damp cloth to remove detergent, and wipe dry. **DO NOT IMMERSE THIS UNIT TO WASH OR RINSE.**

Care, Maintenance, and Cleaning for plungers and Hoppers

The plungers and hoppers of your Type K are precision instruments built from alloy steels and aluminum. They should be handled with care to insure continued satisfactory performance.

When cleaning aluminum, selection of the right type cleaner is your most important consideration. Any household dish washing detergent which is safe for aluminum does a good job of cleaning and does not attack aluminum. Strong Alkali cleaners, such as lye,

soda ash, and tri-sodium phosphate, will discolor or even corrode aluminum even in weak solutions.

DO NOT Handle roughly or drop on hard surfaces.

DO NOT Mix with other utensils in the sink when washing.

DO NOT Allow to rust. Always wash parts thoroughly. Dry completely and lubricate with mineral oil or liquid shortening before storing or reinstalling in unit.

DO NOT Force the machine if it becomes jammed. Disassemble and remove any obstruction to prevent damage to the plunger.

Washing Plungers and Hoppers by Hand:

1. Remove plunger from hopper.
2. Use plenty of warm water.
3. Add cleaner approved for aluminum in concentrations recommended by manufacturer.
4. Presoak to loosen stubborn or dried-on deposits.
5. Use a non-scratching plastic scour cloth to remove soil and restore luster.
6. Rinse in clear hot water (170-190 deg.)
7. Wipe completely dry.
8. Dip plungers in mineral oil or liquid shortening to prevent rust and sticking.

NOTE: "O" Rings are not used on plungers for Type K Depositors

Care and Cleaning of Cutters and Dispensers

The most important thing when cleaning aluminum is the selection of the right type of cleaner. Strong alkali cleaners such as lye, soda ash, and tri-sodium phosphate discolor and corrode aluminum, even in weak solutions. A detergent which contains an inhibitor to prevent the attack on metals, such as those listed below, does a good job of cleaning and does not attack the aluminum.

List of Approved Cleaners for Aluminum

1. Aluminum Cleaner NE-6	Enthone, Inc.	New Haven, CT
2. Cascade	Proctor and Gamble	Cincinnati, OH
3. Clensco A&T	Cowles Chemical Co.	Cleveland, OH
4. Finish	Economics Laboratory	St. Paul, MN
5. Flash-Dri Cleaner	Klenzade Products, Inc.	Beloit, WI
6. Kan Wash	Wyandotte Chemicals	Wyandotte, MI
7. Magnus N Z L	Magnus Chemical Co.	Garwood, NJ
8. Naccanol NR Flakes	National Aniline Division	New York, NY
9. Rinse Aid	Calgon, Inc.	Pittsburgh, PA
10. West Foam Cleaner	West Disinfecting Co.	Long Island, NY

3

Maintenance

Following are some maintenance and operating hints:

- **DO NOT** at any time use force to assemble or operate the machine.
- If machine sticks, disassemble to remove obstruction or check to determine cause and correct same.
- Once each week lubricate the operating cams by putting several drops of oil between trip arms when crank case is held with trip arms pointing up.
- When cleaning machine after use, do not wash or rinse crank case by immersing in water. Use a damp cloth only.

FRENCH PLUNGER

CARE & MAINTENANCE

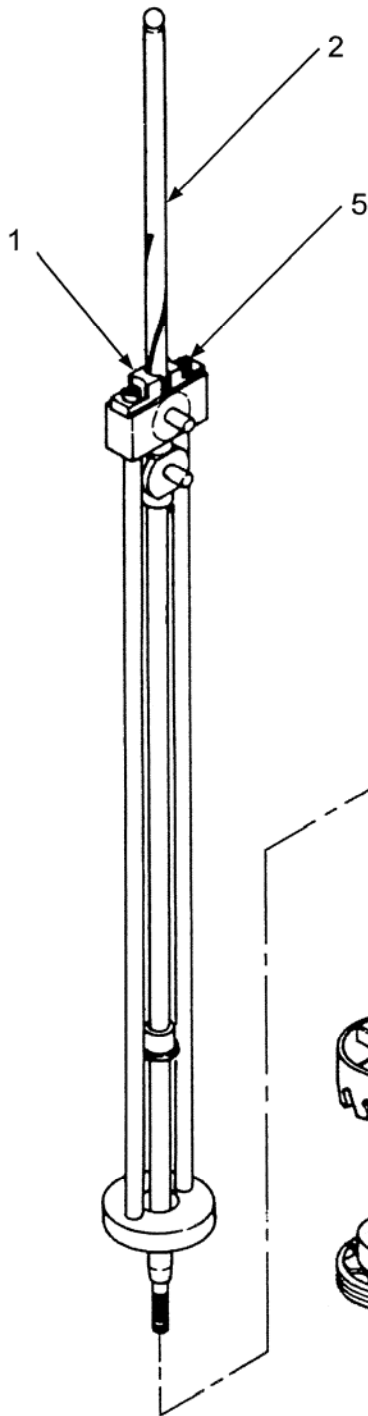

The French Plunger is a delicate, precision piece of equipment and must be handled with extreme care.

Before each use, put one drop of good quality lubrication oil on the gibs (1), so the grooved center rod (2) can slide easily.

After each use, unscrew the lower piston (3) and remove the former (4). Remove gibs (1) and screws (5). Thoroughly wash and dry all parts. Reassemble as shown. Apply cooking oil to assembly to prevent rust.

To Avoid Damage:

- Do not handle roughly
- Do not drop on hard surfaces
- Do not wash in the same sink as other utensils.
- Keep all parts coated with cooking oil to prevent rust.

4

Donut Making Helps

Tips on Making Quality Cake Donuts

- Use the correct batter temperature.

In general, the correct batter temperature is 75°-80°F/24°-27°C. Check the mix manufacturer's instructions, as the recommended temperature range may vary.

If the batter is too warm, the donuts will lack volume and may "ring out" or be misshapen. If the batter is too cold, the donuts will stay under the shortening too long, fry too slowly, and crack open or ball up. They may also absorb excess shortening and lose volume.

- Use the correct floor time.

A floor time of 10 minutes between mixing and cutting allows the baking powder to react with the water. This helps the donuts attain the proper volume and absorb the proper amount of shortening.

If the floor time exceeds 30 minutes, the mix will gas off, the donuts will lose volume and shape and will absorb too much shortening.

- Use the correct frying temperature.

The correct shortening temperature for frying is 370°-380°F/188°-193°C.

If the shortening is too hot, the donuts will fry too quickly on the outside and will lose volume. The donuts may also become dense inside.

If the shortening is too cold, the donuts will spread too rapidly, will form large rings, will tend to crack open, will be too light in appearance, and will absorb too much shortening.

- Maintain the proper shortening level. We recommend a distance of 1 1/4" between the cutter and the shortening.

If the shortening is too deep, the donuts may not turn over when they reach the turner, causing them to cook unevenly.

If the shortening is too shallow (too far below the cutter), the donuts may not drop flat, may turn over while submerging and surfacing, and may become irregular, cracked, or rough-crusted.

- Ensure that the donuts absorb the right amount of shortening.

Donuts should absorb 1-1/2 to 3 oz/42 to 85 g of shortening per dozen, depending on their weight. You can achieve proper absorption by following tips 1-3.

- If the donuts do not absorb enough shortening, they will not keep well.

If they absorb too much shortening, they will lose volume and may become misshapen. If this happens, follow tips 1-3, mix the batter a little longer than usual, turn the donuts as soon as they become golden brown, and turn the donuts only once.

TABLES AND FORMULAS USED IN DONUT MAKING

Calculating Correct Water Temperature

The following is an example of how to calculate the correct water temperature to use. You must use your own room temperature, dry mix

temperature, desired batter temperature, and, if you are making yeast-raised donuts, estimated temperature increase during mixing.

	Cake Donuts		Yeast-Raised Donuts	
	°F	°C	°F	°C
Room temperature	72	22.2	72	22.2
Dry mix temperature	<u>+70</u>	<u>+21.1</u>	<u>+70</u>	<u>+21.1</u>
Total A	142	43.3	142	43.3
Desired batter temperature	75	23.9	80	26.7
	<u>x3</u>	<u>x3</u>	<u>x3</u>	<u>x3</u>
Total B	225	71.7	240	80.1
Total B	225	71.7	240	80.1
-Total A	<u>-142</u>	<u>-43.3</u>	<u>-142</u>	<u>-43.3</u>
Desired water temp. for cake donuts	83°F	28.4°C	98	36.8
			↓	↓
			98	36.8
Temperature increase during mixing (average: 30°F/17°C)			<u>-30</u>	<u>-17</u>
Desired water temperature for yeast-raised donuts			68°F	19.8°C

Ratios of Plunger Sizes to Donut Weights

The weights given are for donuts without icings or other toppings. They are provided for reference only, as weights vary according to the density of the batter.

Plunger Size	Donut Weight per Dozen
1"	5-8 oz/142-227 g
1 7/16"	10-17 oz/283-482 g
1 9/16"	14-21 oz/397-595 g
1 13/16"	19-23 oz/539-652 g

Temperature Conversion

To convert temperatures from Fahrenheit to Celsius, subtract 32 from °F and divide the result by 1.8. For example, $212^{\circ}\text{F} - 32 / 1.8 = 100^{\circ}\text{C}$. To convert temperatures from Celsius to Fahrenheit, multiply °C by 1.8 and add 32 to the result. For example, $(100^{\circ}\text{C} \times 1.8) + 32 = 212^{\circ}\text{F}$.

°F	°C	°F	°C
55	12.8	340	171.1
60	15.6	345	173.9
65	18.3	350	176.7
70	21.2	355	179.4
75	23.9	360	182.2
80	26.7	365	185.0
325	162.8	370	187.8
330	165.6	375	190.6
335	168.3	380	193.3

Batter Temperature Chart (Fahrenheit)

Flour Temperature	Water Temperature
55°F	89°F
56°F	88°F
57°F	87°F
58°F	86°F
59°F	85°F
60°F	84°F
61°F	83°F
62°F	82°F
63°F	81°F
64°F	80°F
65°F	79°F
66°F	78°F
67°F	77°F
68°F	76°F
69°F	75°F
70°F	74°F
71°F	73°F
72°F	72°F
73°F	71°F
74°F	70°F
75°F	69°F
76°F	68°F
77°F	67°F
78°F	66°F
79°F	65°F
80°F	64°F

- If flour temperature is above 80°F, use ice water.
- If shop is extra cold, add 2°F to indicated water temperature.
- If shop is extra warm, subtract 2°F from indicated water temperature.



Donut Cutter Type N

Technical Supplement

Belshaw Bros., Inc.

814 44th Street NW, Suite 103

Auburn, WA 98001 USA

Phone: (206) 322-5474 • Fax: (206) 322-5425

Email: service@belshaw.com • <http://www.belshaw.com>

If you accept the machine from the shipping company, you are, in effect, saying that the machine is in good condition, and you must pay for the machine. The freight company has accepted responsibility for the safe delivery of our machines. **For your protection**, inspect the machine to see that no parts are bent, scratched, or otherwise damaged. If any damage has occurred in shipping, file a freight claim with the shipping company immediately.

IMPORTANT

Keep this manual for reference purposes.

EQUIPMENT RECORD

Please provide the information below when you correspond with us about your machine.

Purchased by _____

Installed by _____

Date of installation _____ Model number _____

Serial number _____

011108

MN-1543EN

Belshaw Bros., Inc.

814 44th Street NW, Suite 103

Auburn, WA 98001 USA

Phone: (206) 322-5474 • Fax: (206) 322-5425

Email: service@belshaw.com • <http://www.belshaw.com>

Contents

1	Installation	1
	Wall Mount	1
	Fryer Mount	2
	Assembly	2
2	Maintenance	3
	Factory Parts & Repair Service	3
3	Appendix	4
	Parts List Drawing Insert Page	Insert

Preface

The Type N Variety Cutter is designed to cut cake donut products and deposit them in a variety of smaller fryers. It is designed to be mounted on a wall or on a fryer mount.

During production, the operator must move the Cutter, holding the guide handle, to deposit donuts in the desired locations in the fryer. The operator must work safely at all times and read this manual and follow its instructions and warnings.

A thorough understanding of how to install, maintain, and safely operate the Type N Variety Cutter will prevent production delays and injuries. Heed the following warnings and all other warnings that appear in this manual:

- Make sure the machine is mounted securely. Doing so will prevent the machine from tipping over or falling, which could cause serious injury.
- When the machine is column-mounted on a fryer, make sure the fryer is securely fastened to the floor. If the fryer is not fastened to the floor, the weight of the cutter could cause the fryer to tip over, resulting in serious burns, other injury, or death.
- To avoid damaging the machine, never use force to assemble, disassemble, operate, clean, or maintain it.
- Be careful never to get shortening, water, or other materials on the floor. If anything does get spilled on the floor, clean the area immediately. Materials on the floor can cause people to slip or fall, resulting in serious injury or loss of life.

WARNING

Never put your hand in the hopper or between trip arms while machine is being operated.

DANGER!

When the cutter is column mounted, the fryer must be securely fastened to the floor to prevent tipping or overturning the fryer. If the fryer is tipped, SERIOUS BURNS or other injury can occur.

This machine is designed to be used on either a wall mount or a fryer mount. This should be specified when the machine is ordered from the factory. If the mounting is not specified, the fryer mount will be shipped.

Wall Mount consists of:

Wall Plate #0004

Wall Arm Pin #0011

Set Collar #0121

Arm Bushing #0120

6 Lag Bolts, 5/16-1 1/2"

Fryer Mount consists of:

Column, 1 1/8" Dia., #0132-2 (20" Long)

Or #0132-3 (48" Long)

Set Collar #0121

2 Fryer Brackets; #591-16 or #0133

4 Mounting bolts, 1/4-20 x 1, NC

Installation of Wall Mount

It is necessary to provide a good solid support for mounting the machine to the wall. We suggest the use of a 2 x 4" timber, securely fastened to the wall. This 2 x 4 should be long enough to extend upward from the floor to a distance approximately 18" higher than the top of the frying kettle.

If the wall is wood, the 2 x 4 should be securely spiked to the wall. If the wall is brick, holes should be drilled, and the 2 x 4 fastened by lag bolts with expansion bolt shields.

1. Set the frying kettle in position directly in front or a little to the right of the wall support, and approximately 6" from the

wall. The Variety Cutter can be mounted from either side of the kettle or between 2 kettles.

2. Lay a straight edge, (a board will do) across the kettle top to the 2 x 4.
3. Measure up 9" and mark center which will be the correct height and position for the top hole in the wall plate. Drill a 1/4" hole at this point and fasten the wall plate with the lag screws which come with the machine.
4. Determine the correct vertical position of the wall plate, then screw the plate down securely to the 2 x 4 using all 6 screws.
5. To locate the curved arm section in place on the wall plate, the large bushing should be installed in the curved arm section. The set collar should be installed on the large bushing under the curved arm. Then slide the 1/2" pin through the upper bearing hole on the wall plate, through the bushing and then through the lower bearing hole on the wall plate. Place washer provided on the upright pin to serve as a thrust bearing. Oil pin lightly with light machine oil.
6. Set the small straight arm in place on the pin of the first bracket arm. This should be also mounted so that the pin is pointing up. Place 1/2" washer provided on the pin. Oil pin lightly with light machine oil.
7. The donut cutter should be mounted on the pin of the straight arm. Adjust the set collar under the curved arm to give the proper clearance. (A) The guard flange of the hopper base when mounted on the machine should just clear the rim of the

fryer. (B) The bottom of the cutter should be 1" to 1 ¼" from the surface of the shortening.

Installation of Fryer Mount

(NOTE: For mounting to 616A or 616"AT fryers, see instructions for Cut-N-Fry Combination).

This equipment is designed as a universal unit, and can be mounted on the corner of most fryers. The mounting brackets should be mounted on the back corner on the opposite side of the drain tray. They can be fastened to the fryer case using ¼" bolts. Washers and nuts should be used if the mount is made on the sheet metal case.

1. The brackets should be mounted so as to be approximately 12" apart if possible. The upper bracket should be as near the top of the fryer as possible.
2. After brackets are installed, the mounting column should be put in place so that it rests on the surface on which the fryer is sitting. Then lock with the set screws in the mounting brackets.
3. Slide set collar into rod (pin up and toward the back for countertop fryers; pin down for floor models). Place so that top of collar is 6" above the rim of the fryer. This will give approximate location. Oil rod above set collar lightly with machine oil.
4. Place bracket arm with large hole on the rod, sliding down until it rests on the set collar. This should be set so that the 4" long pin is pointing up. Place nylon washer provided on the pin to serve as a thrust bearing. Oil pin lightly.
5. Set the small straight arm in place on the pin of the first bracket. This should be also mounted so that the pin is pointing up. Place the nylon washer provided on the pin. Oil lightly with machine oil.

6. The donut cutter should be mounted on the pin of the outer arm. Adjust the set collar under the inner arm to give the proper clearance. (A) The guard flange of the hopper base, when mounted in the machine, should just clear the rim of the fryer. (B) The bottom of the cutter should be 1" to 1 ¼" from the surface of the shortening.

To Assemble the Cutter

1. Position hopper on the small bracket arm setting mounting hole over the bracket pin.
2. Insert hopper base in bottom of cylinder, pushing up to force lock pin out. When hopper base is fully inserted, rotate until lock pin goes into place.
3. Position crank case on the double locating studs. Do not push the crank case fully into position, holding back approximately ½". Start the lock nut on the end of the threaded locating pin.
4. Insert the plunger by passing rods through the opening in the hopper center and having the plunger bearing above the hopper arch. Lower the plunger bearing into the bearing seat in the hopper center. Align the arms with the plunger pins. When the forks on the trip arms are in line with the plunger pins, tighten the crank case locknut which pushes the crank case into position. Then tighten lock screw on the hopper center bearing to hold plunger bearing in place.

Following are some maintenance and operating hints:

- **DO NOT** at any time use force to assemble or operate the machine.
- If machine sticks, disassemble to remove obstruction or check to determine cause and correct same.
- Once each week lubricate the operating cams by putting several drops of oil between trip arms when crank case is held with trip arms pointing up.
- When cleaning machine after use, do not wash or rinse crank case by immersing in water. Use damp cloth only.

number, and the name of the contact person when a cost estimate has been determined. In most cases, the machine can be shipped back, freight collect, within five days.

Factory Parts and Repair Service

Replacement Part Orders (Include the following information with your order):

1. Model number of your machine
2. Serial number of your machine
3. Voltage, phase and hertz (if applicable)
4. Part number, part name, description, size, etc. (if applicable)
5. Quantity desired

Factory Rebuild Service:

If your machine becomes badly worn or seriously out of adjustment, we have a complete rebuild and repair service. Call the service department for a Return of Goods Authorization number (RGA#). Return your machine to the factory (with RGA# on the outside of the box, and on all the paperwork included), FREIGHT PREPAID, with your instructions, phone

3

Appendix

See Parts List Drawing Insert Page.