

# Self-Actuating Tray Lidder

## Key Features:

- Large capacity heat-seal tray lidder designed for use with heat-seal coated, printed or unprinted, plastic film material.
- For use with flat-flanged paperboard or plastic trays.
- Complete heat-seal control of time, temperature, and pressure.
- Unique air actuator providing high seal force and floating hot platen.
- Auto-Seal with Auto-Eject.
- Tray lifter integrated in tray carrier.
- Swing-away hot platen.
- Stainless steel and anodized aluminum construction.
- Interchangeable tray carriers for trays up to 10" x 12" x 3.3" deep.
- Additional tray sizes may be compatible; please contact your Account Manager.



## Benefits

- Improves merchandising, creates your own "brand", sells more product.
- Lowers packaging costs (film lidding vs snap-cover domes).
- Improves package performance, leak-resistant, microwavable/ovenable.
- Assures consistent seal integrity.
- Simple operation, push tray carrier in to activate the sealing process, upon completion the tray carrier automatically ejects to the starting position. Allows sustained seal rate of eight packages per minute (with optional accessories).
- Easy cleaning and high durability for continued use in food preparation environment.
- Flexible, quick change-over in seconds.



U.S. Patent #5,791,120, #5,784,858, #5,946,887, #6,571,534

# Self-Actuating Tray Lidder

Model 1708-N

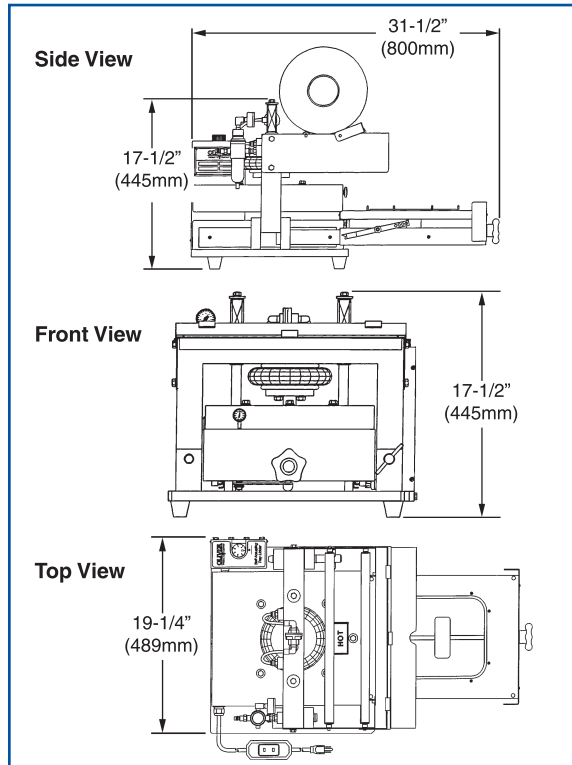

## SPECIFICATIONS:

### Tray Capacities:

10" x 12" maximum top-outside dimension tray.

3.3" maximum outside dimension tray depth.

Custom tray carrier tooling available to match your trays.

**Temperature Range:** 50°F (10°C) to 410°F (210°C)

### Dimensions:

19.3" (489mm) overall width (front)

31.5" (800mm) overall depth

17.5" (445mm) overall height

**Electrics:** 115 VAC, 8 AMPS, single phase, 50/60 Hz

**Air:** 100 PSI at 0.5 CFM minimum, 150 PSI maximum,  
40 PSI minimum

**Agency Approvals:** USDA, NSF, UL/UL-C.

## OPTIONAL ACCESSORIES:

**Lidding Dispenser:** For roll lidding, pre-die-cut and connected by tear-away perforation.

Roll capacities: 9.5" maximum outside-diameter roll,

12.5" maximum width roll

(lidding available from Oliver Products Company).

**Workstation Stand:** Incorporates tables at tray carrier level and puts the 1708 Self-Actuating sealer at 36" height to provide maximum sealing rate when used in conjunction with standard food processing work tables. Lockable casters provide stability in the heat sealing process.

**Air Compressor:** Compact, quiet, 115 VAC, 3.7 AMPS, 60 Hz, 125 PSI, 0.9 CFM @ 100 PSI, oil-less air compressor sized to work with the 1708 Self-Actuated Tray Lidder in places where "shop air" is unavailable.

**Large Capacity:** For large tray applications a 12.0" x 13.5" hot platen is available.

The information contained herein is correct to the best of our knowledge. The recommendations or suggestions are made without guarantee or representation as to results. Freedom from any patent owned by Oliver Products Company or other is not to be inferred.

© Trademark of Oliver Products Company

Above specifications subject to change without notice

**Oliver® Products Company**  
445 Sixth St. N.W.  
Grand Rapids, MI 49504-5298  
616/456-7711  
1/800/253-3893  
616/456-7791 FAX  
E-mail: [www.oliverproducts.com](http://www.oliverproducts.com)

8/07

**Oliver® Products Company • 445 Sixth Street N.W. • Grand Rapids, MI 49504-5298**

Phone: 616/456-7711 • Toll-Free: 800/253-3893 • 616/456-7791

Web: [www.oliverspeedseal.com](http://www.oliverspeedseal.com) • Email: [foodpkgsales@oliverproducts.com](mailto:foodpkgsales@oliverproducts.com)