

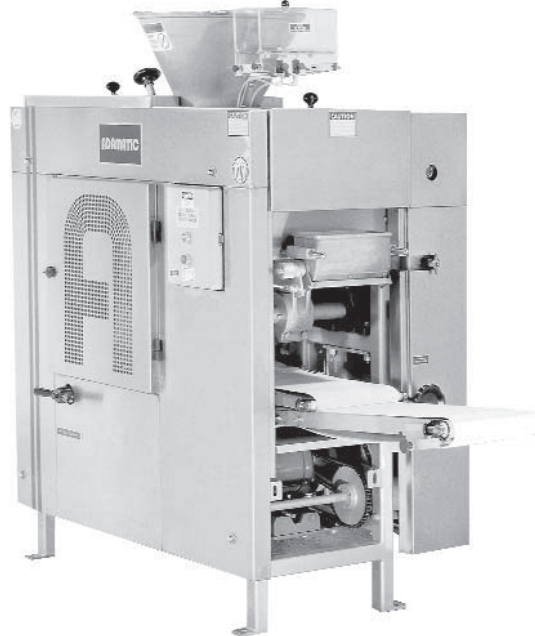

Divider/Rounder

AADR-2



Standard Features:

- Speeds up to 40 strokes per minute
- Fully adjustable hydraulic main piston, assuring accurate scaling with minimal dough punishment
- Mechanical variable speed and rounding control
- Stainless steel covers that are electrically interlocked for safety
- Adjustable gravity feed oiling system
- Flour duster
- Simple weight adjustment
- Easy to clean and maintain
- BISCC approved
- UL listed control panel
- ADR tool group

Optional Features and Accessories:

- Digital stroke counter

DIVIDING RANGES

- 1 pocket: (bread) 10-19 oz.
- 2 pocket: (bread and rolls) 1-8 oz.
- 3 pocket: (rolls) 1-3 oz.

Belshaw Adamatic Bakery Group
814 44th Street NW, Suite 103
Auburn, WA 98001
Phone: 800-578-2547 Fax: 206-322-5425
www.adamatic.com



Divider/Rounder

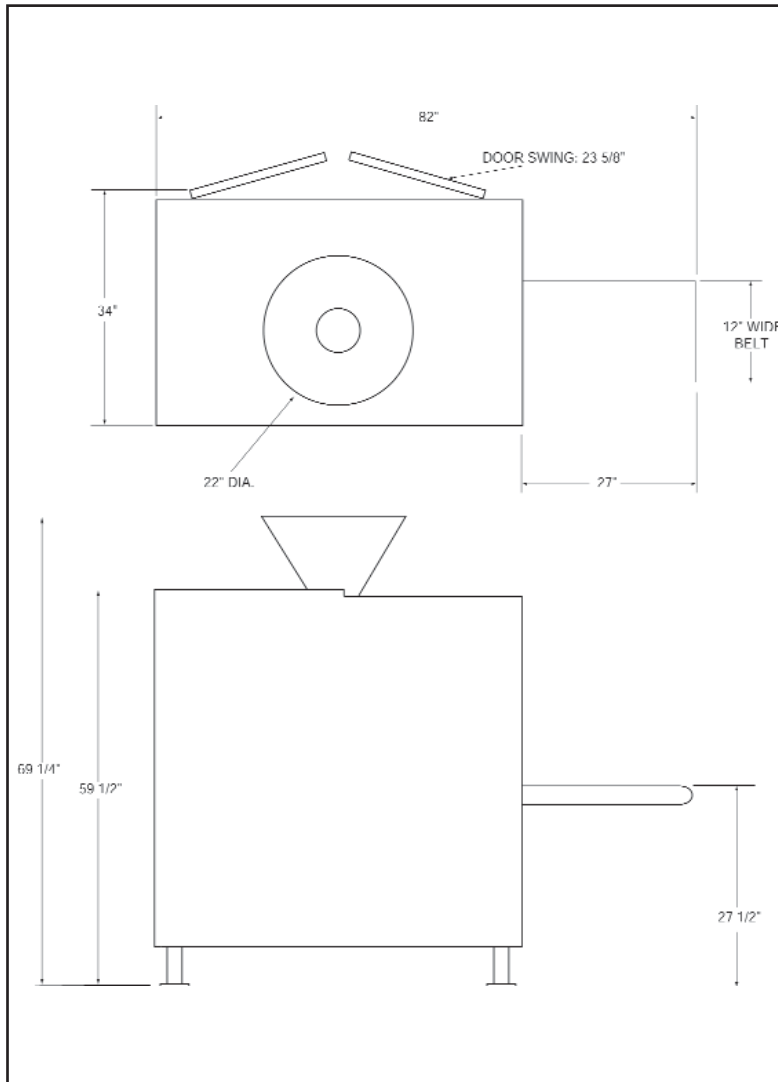

TECHNICAL DATA

Capacity Range 4,800 pieces per hour

Weight Range 1-19 oz.

POWER SUPPLY

220v, 3 phase, 60 Hz, 20 amp

CRATED SHIPPING DATA

Weight, net 2,025 lbs.

Weight, crated 2,150 lbs.

Volume, crated 162 cubic feet

We reserve the right to change specifications and product design without notice. Such revisions do not entitle the buyer to corresponding changes, improvements, additions or replacements for previously purchased equipment.

